



POWER BREAK® Walking-Beam Mechanical Interlock

For 800, 1600, 2000, 2500 and 3000A
Frames – Stationary Only

CAUTION: Before inspecting or beginning any maintenance work on the breaker, it must be disconnected from all voltage sources, both power and control, and breaker must be off (open)

NOTE: This accessory is not UL listed. Installation voids the UL listing.

INSTALLATION

Removal of Breaker Knockouts, Figures 1 and 2.
(Use adjacent KO holes in breakers.)

1. Set breakers to OFF position.
2. Working from back of breaker, drive a small screwdriver past edge of KO and through connecting web. Pry out KO.
3. Remove any remaining flash, making sure debris does not fall inside the breaker.

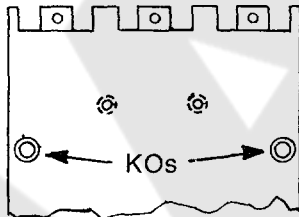

Figure 1. 800, 1600 and 2000A frames.

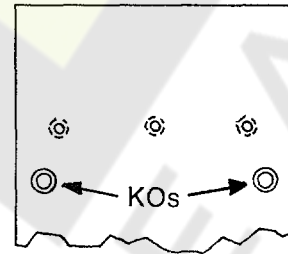

Figure 2. 2500 and 3000A frames.

DRILLING HOLES IN MOUNTING PANEL

For 800, 1600 & 2000A Frames

Drill holes in mounting panel as shown in Figure 3.

For 2500 & 3000A Frames

Drill holes in mounting panel as shown in Figure 3a.

MOUNTING MECHANICAL INTERLOCK

Mount and adjust as shown in Figure 4.

MOUNTING BREAKERS

1. Set breakers in OFF position.
2. Mount breakers.
3. Check that plungers do not bind in panel holes or breaker KO holes:

OPERATION CHECK

1. With one breaker ON and the other breaker OFF, there should be slight "play" in the interlock system to assure that a "bottomed out" condition does not exist.
2. Determine that the interlock prevents both breakers from being turned ON at the same time.
3. If readjustment of plungers is required, perform as outlined in Figure 4.
4. Recheck operation of interlock as described in 1 and 2, directly above.

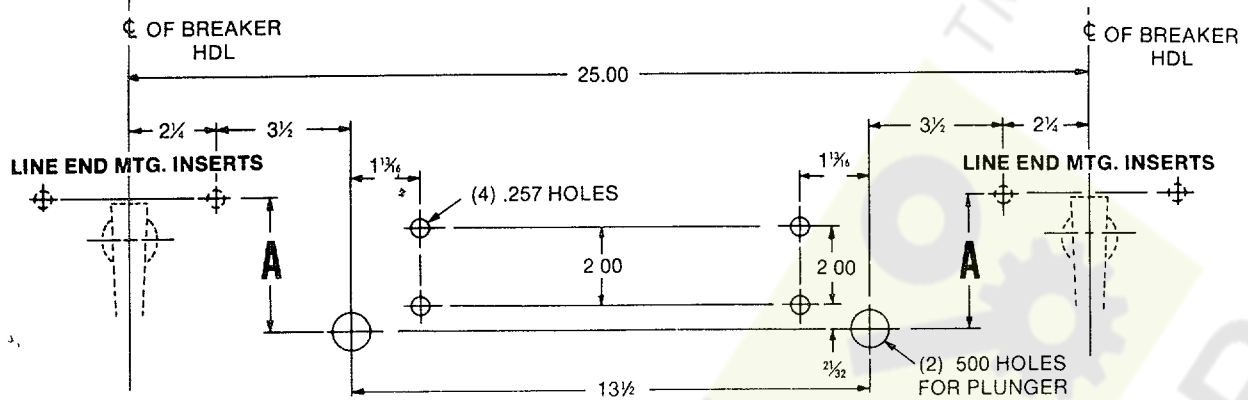

ENVELOPE SIZE	A
800 FRAME	3 ¹ / ₂
1600 & 2000 FRAME	3 ⁵ / ₈

Figure 3. Drilling mounting panel 800, 1600 and 2000A frames

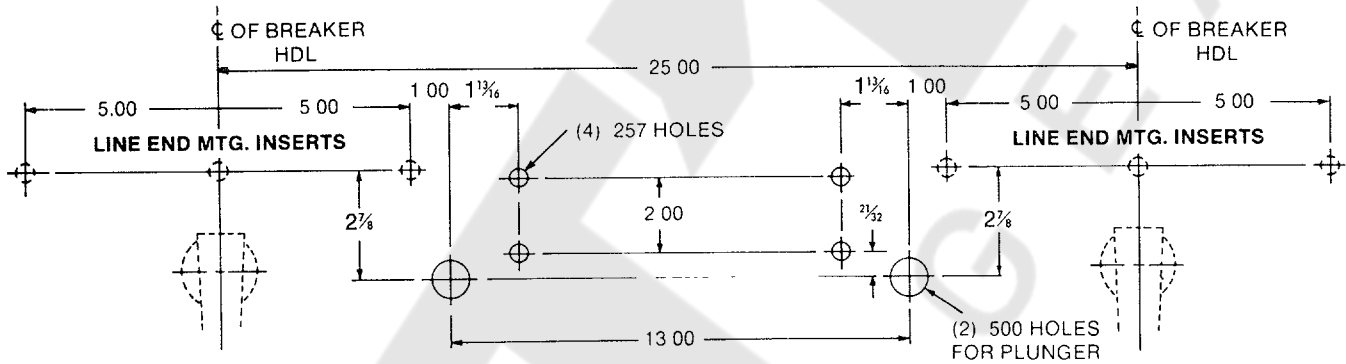
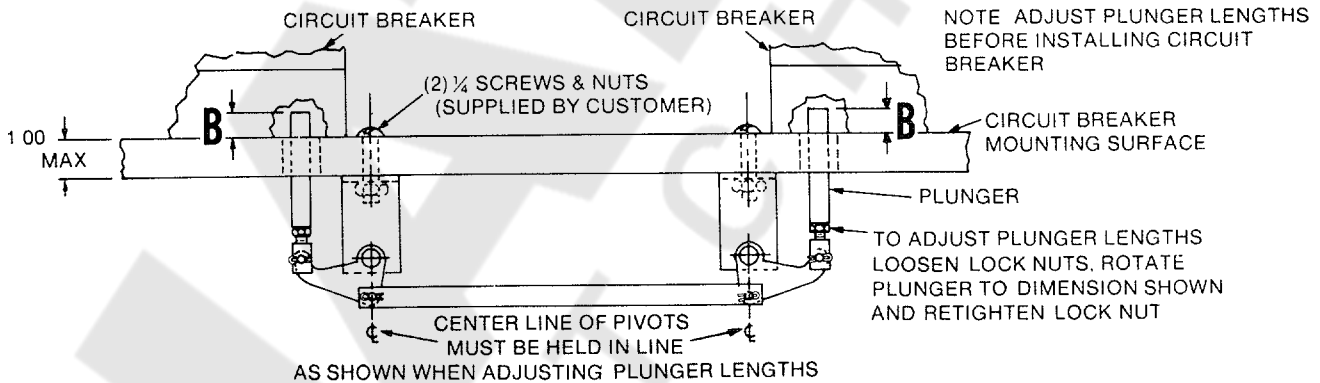

Figure 3a. Drilling mounting panel 2500 and 3000A frames



ENVELOPE SIZE	B
800, 1600 & 2000A FRAMES	1 ¹ / ₂
2500 & 3000A FRAMES	1 ¹ / ₂

Figure 4. Mounting interlock 800, 1600 and 2000A, 2500 and 3000A frames

These instructions do not purport to cover all details or variations in equipment nor to provide for every possible contingency to be met in connection with installation operation or maintenance. Should further information be desired or should particular problems arise which are not covered sufficiently for the purchaser's purposes, the matter should be referred to the GE Company



GE Electrical Distribution & Control