

INSTRUCTIONS FOR REPLACING HANDLE HUB ASSEMBLY ON SPB BREAKERS

CAUTION: The breaker must be completely de-energized and disconnected from electrical circuit. The breaker mechanism must be discharged and main contacts open.

- 1) Remove handle and breaker cover as per instructions on pages 19 and 20 of I.L. 15082.
- 2) Remove large outside retaining ring, Item 17, from end of clutch sleeve (Item 4).
- 3) Remove outer flange, Item 8, by pulling straight out while turning counter-clockwise. Handle drive spring, Item 15, should come out with outer flange.
- 4) Remove hub, Item 16, by pulling straight out. Handle return spring, Item 13, and separator, Item 9, should come out with hub.

Note: Breakers built after May 1, 1981, and breakers already equipped with stop, Item 1, may go to Step 12).

Breakers without stop, Item 1, complete Steps 5) through 17).

- 5) Pull breaker clutch spring, Item 14, off of sleeve, Item 7, by turning it clockwise (to release tension) and pulling straight away from mechanism.
- 6) Drive .188 dia. spring pin, Item 10, out and remove entire assembly from cam shaft.

Note: Note when re-assembling springs onto handle assembly, use a light oil such as LPS-2 or WD-40 for rust prevention. Do not use a silicone-based oil. This will cause clutches and brake to slip.
- 7) Slide .200 tk. spacer, Item 3, over cam shaft until it rests against bushing on side frame of mechanism.
- 8) Slide stop, Item 1, onto cam shaft, so that it rests over large pin on mech frame.
- 9) Slide added spacer (.094 tk.) onto cam shaft until it rests against stop, Item 1; Note: .094 tk. spacer is not shown in assembly.
- 10) Replace hub assembly opposite way of disassembly.
- 11) Slip assembly (Items 5, 6, 12, 7, 4, 14) onto cam shaft and drive spring pin, Item 10, into cam shaft until spring pin is within sleeve, Item 7. The assembly should be free to move clockwise, about 5°.

- 12) Insert separator, Item 9, and return spring, Item 13 into hub. Insert key, Item 2, into groove of hub. Be sure spring end is inserted (return spring) Item 7, into hole in separator, and lanced ear on separator is pointing in proper direction, see figure.
- 13) Slide hub, Item 16, on clutch sleeve, Item 4, by pushing straight in. Be sure spring end, Item 13, is inserted into hole on sleeve, Item 7. Key, Item 2, should now be resting on stop, Item 1.
- 14) Turn hub clockwise slightly and hold in that position. Slide outer flange, Item 8, over clutch sleeve, Item 4, by pushing straight in while turning flange counter-clockwise. Align pins, Item 11, in hub with holes in outer flange and push entire assembly toward mechanism while allowing whole hub assembly to rotate slowly counter-clockwise.
- 15) Replace large outside retaining ring, Item 17.
- 16) Replace breaker cover and handle.
- 17) Check clutch operation:
 - Mechanism should fully charge with four full handle strokes
 - Clutch should not slip while charging mechanism
 - When released, handle should return to initial position

A. J. Fishovitz
Rev. 6/21/84
4892H

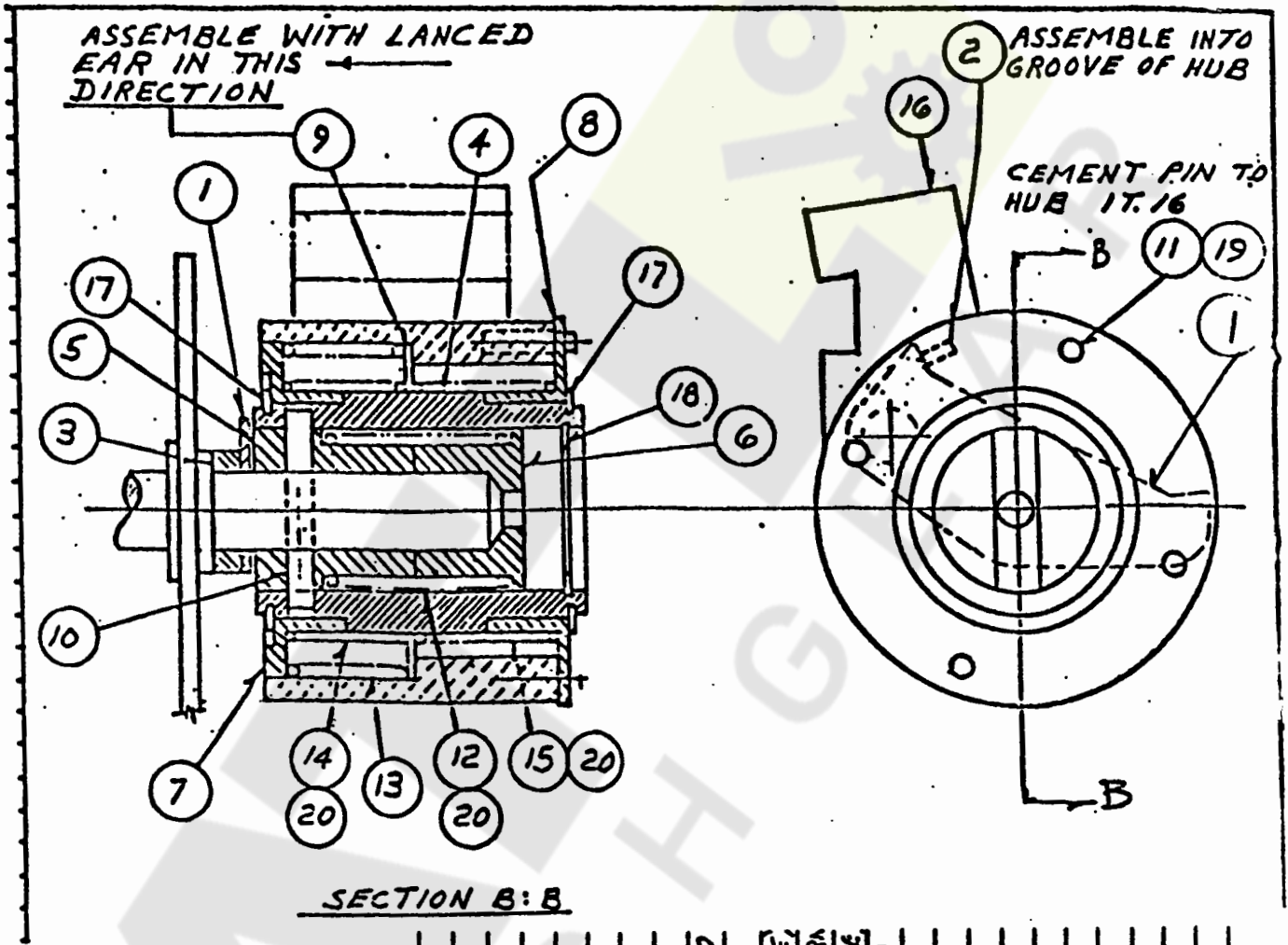

01	STOP
02	KEY
03	SPACER
04	SLEEVE
05	DRUM
06	DRUM
07	DRUM
08	DRUM
09	SEPARATOR
10	SPRING PIN .188 X 1.500
11	PIN
12	SPRING (MOTOR DRIVE)
13	SPRING (HANDLE RETURN)
14	SPRING (HANDLE BRAKE)
15	SPRING (HANDLE DRIVE)
16	HUB
17	RETAINING RING
18	RETAINING RING
19	ADHESIVE
20	LUBRICANT
21	PKG. SPEC. <small>SEE SPRINGED DRAFT PAPER</small>
22	CARTON LABEL
23	INST. SHEET